

**Tower Crane / Grue à tour / Gru a torre
Grúa torre / Guindaste de torre**

Turmdrehkran 71 K

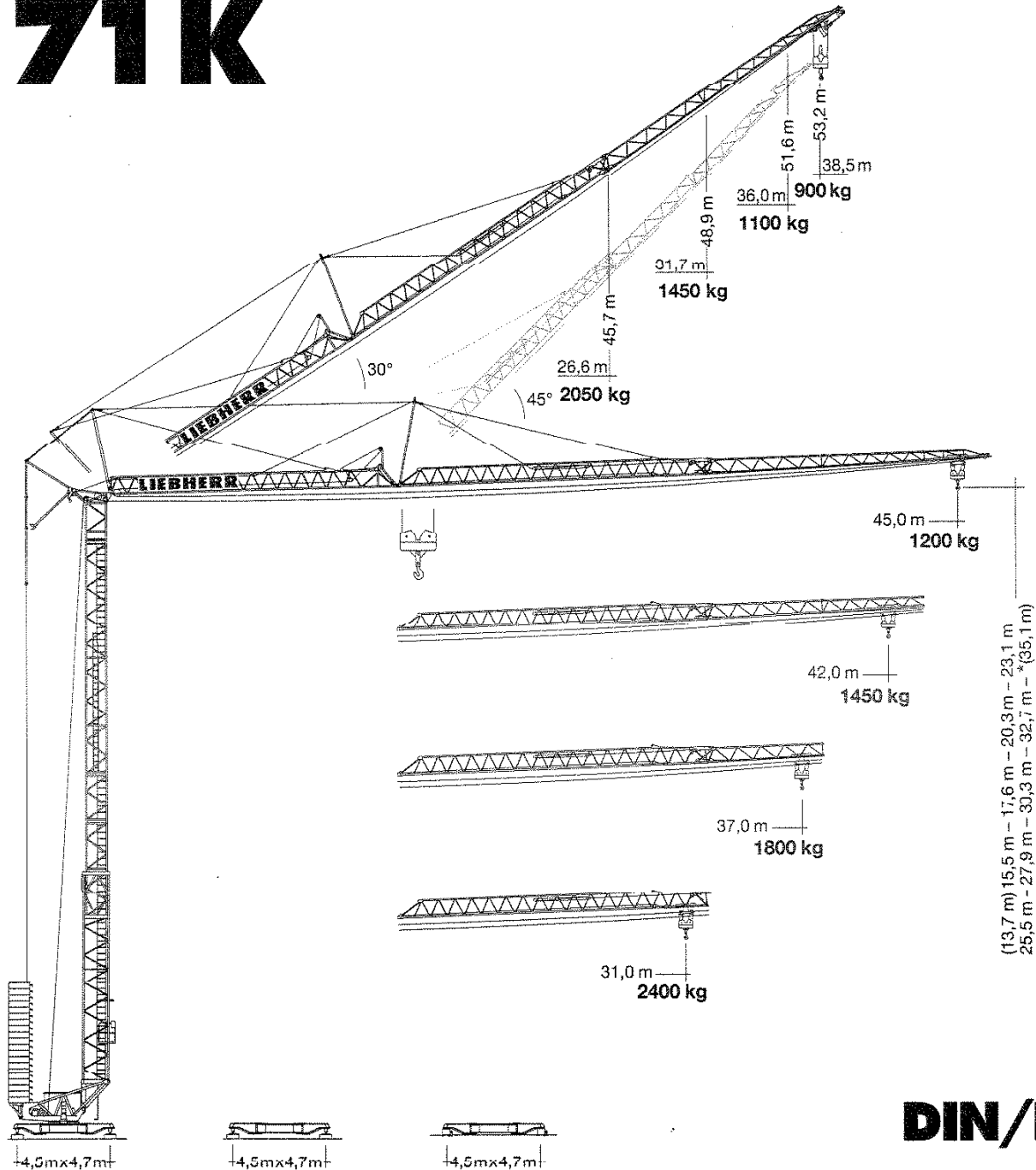

DIN/FEM

1 : 000

LIEBHERR

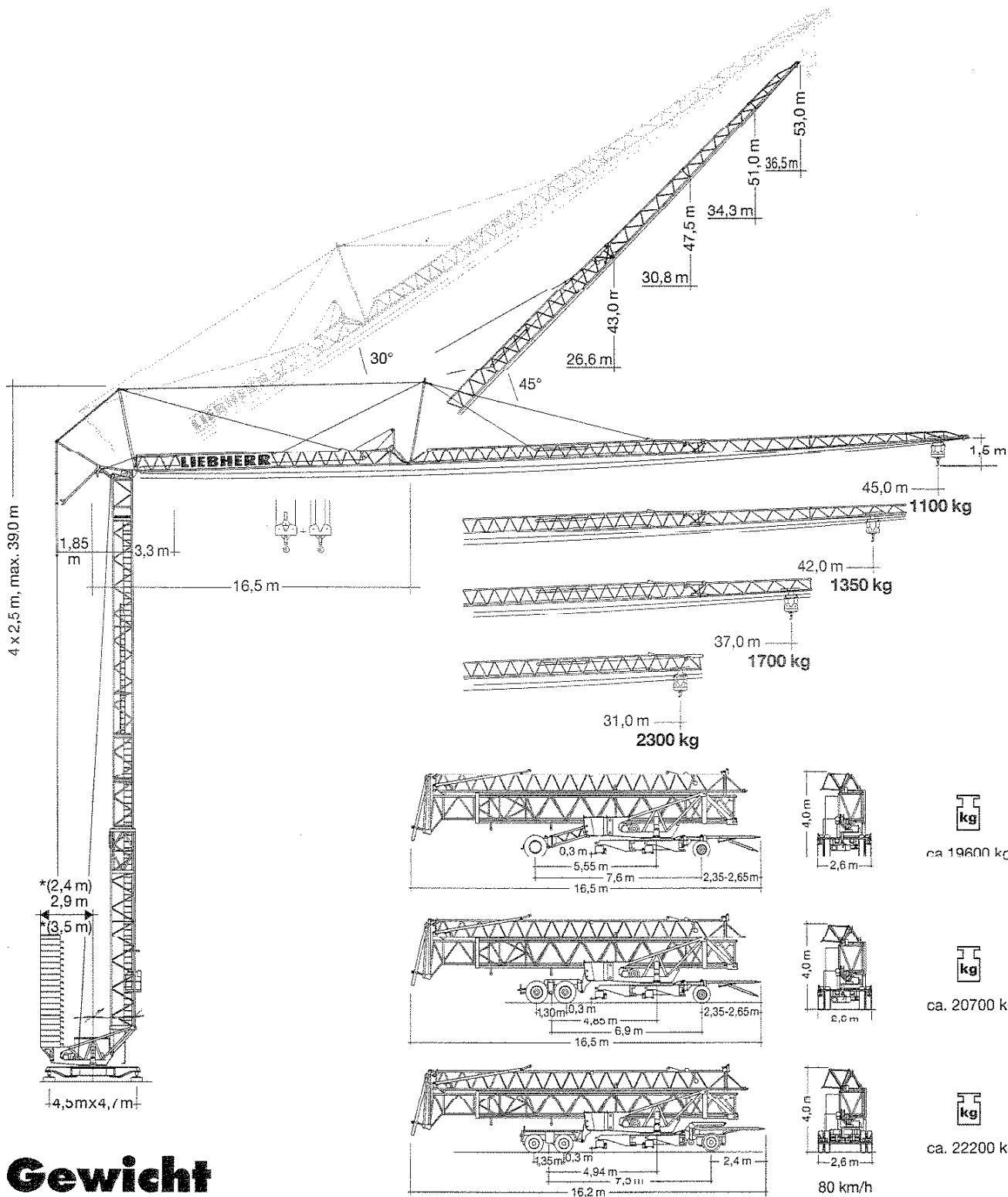

Gewicht

Weight / Poids / Peso / Peso / Pesos

	r = 3,5 m	29280 kg		16500 kg
	r = 2,9 m	36600 kg		
	r = 2,4 m	36600 kg		

* () siehe Betriebsanweisung. / see instruction manual. / voir manuel de service. / vedi manuale d'istruzione. / ver manual de instrucción. / ver manual de instruções.

Ausladung und Tragfähigkeit

Radius and capacity / Portée et charge / Sbraccio e portata / Alcances y cargas / Alcance e capacidade de carga

m	m/kg		2,9/3,5 m																						
			18,0	20,0	22,0	24,0	26,0	28,0	29,0	30,0	31,0	32,0	33,0	34,0	35,0	36,0	37,0	38,0	39,0	40,0	41,0	42,0	43,0	44,0	45,0
45,0	3,3 - 20,3 3050		3050	3050	2790	2530	2310	2120	2040	1960	1890	1820	1750	1690	1630	1580	1530	1480	1430	1390	1350	1310	1270	1240	1200
42,0	3,3 - 22,1 3050		3050	3050	3050	2780	2540	2340	2240	2160	2080	2000	1930	1870	1800	1750	1690	1640	1590	1540	1490	1450			
37,0	3,3 - 23,3 3050		3050	3050	3050	2950	2700	2480	2390	2290	2210	2130	2060	1990	1920	1860	1800								
31,0	3,3 - 25,0 3050		3050	3050	3050	3050	2920	2690	2590	2490	2400														

m	m/kg		2,9/3,5 m																						
			10,0	11,0	12,0	13,0	14,0	16,0	18,0	20,0	22,0	24,0	26,0	28,0	30,0	31,0	33,0	35,0	37,0	39,0	41,0	42,0	43,0	44,0	45,0
45,0	3,3 - 20,0 3000	3,3 - 10,7 6000	6000	5810	5290	4850	4470	3880	3390	3000	2690	2430	2210	2030	1860	1790	1650	1540	1430	1330	1250	1210	1170	1140	1100
42,0	3,3 - 21,7 3000	3,3 - 11,6 6000	6000	6000	5700	5310	4900	4230	3710	3300	2960	2680	2440	2240	2060	1980	1830	1710	1590	1490	1390	1350			
37,0	3,3 - 22,9 3000	3,3 - 12,2 6000	6000	6000	6000	5620	5190	4490	3940	3510	3150	2850	2600	2380	2200	2110	1960	1820	1700						
31,0	3,3 - 24,7 3000	3,3 - 13,1 6000	6000	6000	6000	6000	5610	4850	4270	3800	3410	3090	2820	2590	2390	2300									

m	m/kg		Auslegerstellung 30° / Elevated jib 30° / Flèche inclinée 30° Braccio inclinato a 30° / Pluma inclinada 30° / Lança inclinada 30°																					
			2,9/3,5 m																					
			14,0	15,0	16,0	18,0	20,0	22,0	24,0	25,0	26,0	26,6	28,0	30,0	31,0	31,7	33,0	34,0	35,0	36,0	37,0	38,0	38,5	
45,0	3,1 - 14,9 3000		3000	2970	2760	2400	2120	1890	1700	1610	1530	1490	1390	1270	1220	1180	1120	1070	1030	990	950	910	900	
42,0	3,1 - 16,0 3000		3000	3000	3000	2620	2310	2060	1850	1760	1680	1640	1530	1400	1340	1300	1230	1180	1140	1100				
37,0	3,1 - 17,3 3000		3000	3000	3000	2870	2540	2270	2050	1950	1860	1810	1690	1550	1490	1450								
31,0	3,3 - 19,2 3000		3000	3000	3000	3000	2860	2560	2310	2200	2100	2050												

Geschwindigkeiten

Speeds / Vitesses / Velocità / Velocidades / Velocidades

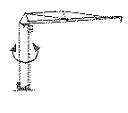
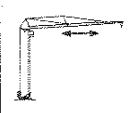
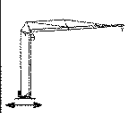
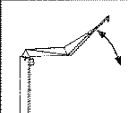
	0 ↔ 0,8 U/min. sl./min tr./min	5,0 kW, EDC
	0 ↔ 60,0 m/min	2,8 kW, FU
	0 ↔ 25,0 m/min	2 x 1,5 kW, FU
	0 - 45°, 105 sec.	3,0 kW, FU

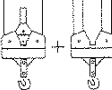
	Stufe / Step / Cran Marcia / Velocidad Velocidade		
	kg	m/min	
	15,0 kW, FU		
	1	3000 6000	5,0 2,5
	2	3000 6000	24,0 12,0
	3	2100 4200	34,0 17,0
4	1300 2600	58,0 29,0	

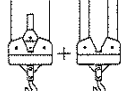
BGL:  2108-0063

	400 V	Hz	kVA
87,0 m	4 x 6 mm ²	50	21,0 (FU)

Technische Daten

Technical data - Caractéristiques techniques

Caratteristiche tecniche - Características técnicas - Datos técnicos

Aufstellvorgang

Erection procedure

Déroulement de montage

Procedimento di montaggio

Procedimiento de montaje

Sistema de montagem

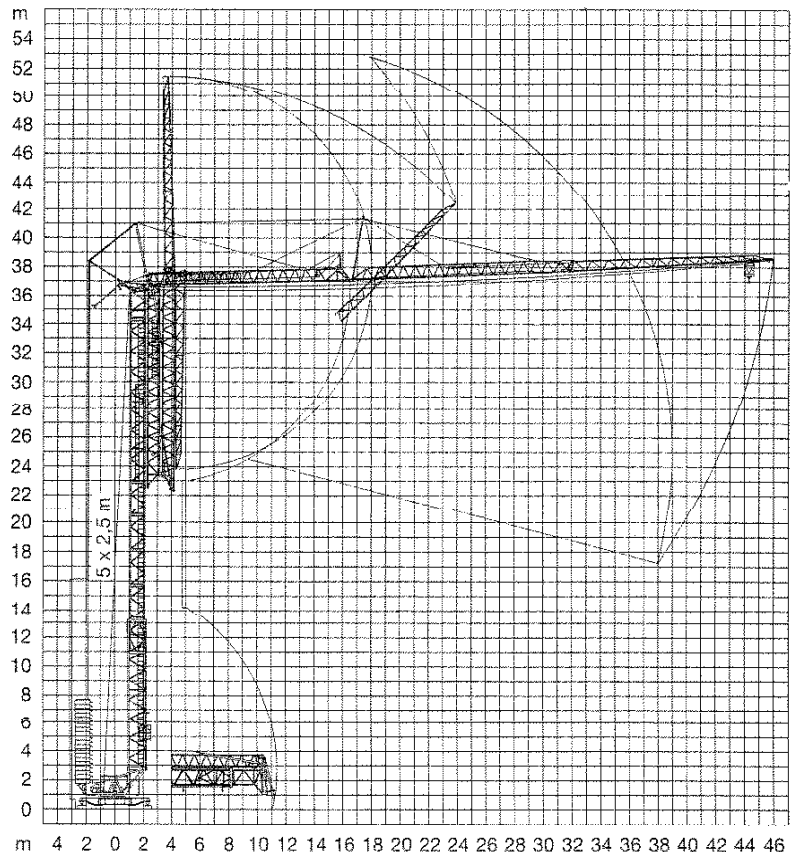

Kolli-Liste

Packing List / Liste de colisage / Lista dei colli

Lista de contenido / Lista de embalagem

Pos. Item	Anz. Qty.		L (m)	B (m)	H (m)	kg		
1	2	Turmstück (ohne/mit Turmauflage*) / Tower section (without/with tower support*) / Élément de mât (sans/avec support de mât*) / Elemento di torre (senza/con pedana di servizio*) / Tramo de torre (sin/con soporte de torre*) / Tramo de torre (sem/com suporte de torre*)			2,50	1,10	1,10	490
2	1*		2,50	1,10	1,10	563 *		
3	1	Ausieger-Verlängerung 31,0 m – 37,0 m Jib extension / Rallonge de la flèche Elemento estensione braccio Prolongación de pluma / Extensão da lança			6,40	1,02	0,88	359
4	1	Ausieger-Verlängerung 37,0 m – 42,0 m Jib extension / Rallonge de la flèche Elemento estensione braccio Prolongación de pluma / Extensão da lança			5,10	1,02	0,70	157
5	1	Ausieger-Verlängerung 42,0 m – 45,0 m Jib extension / Rallonge de la flèche Elemento estensione braccio Prolongación de pluma / Extensão da lança			3,10	1,02	0,50	92
6	1	Transportachse vorne Tra 100 KY 1 Road transport axle front / Essieux de transport avant / Asse di trasporto anteriore / Eje delantero para transporte / Eixo de transporte dianteiro			3,00	1,13	0,97	740
7	1	Transportachse hinten Tra 120 GY 1 Road transport axle behind / Essieux de transport arrière / Asse di trasporto posteriore / Eje trasero para transporte / Eixo de transporte traseiro			1,90	2,50	1,05	1250
8	1	Transportachse Tra 200 GZ 3 / Road transport axle Essieux de transport / Assali par trasporto Eje de transporte / Eixo de transporte			3,10	2,50	1,10	2500
9	1	Kiste mit Seilen und Kleinteilen / Case with ropes and small parts Caisse avec câbles et pièces détachées / Cassa con funi e accessori Caja con cables y piezas sueltas / Caixa contendo cabos e acessórios			1,00	0,80	1,00	160

120 P – 3862 H1 B3 DIN 15018 • BGL 2108-0063 / FEM (Section 1) Krangruppe A3 und OENORM T3 • 01.02 / 6

Konstruktionsänderungen vorbehalten! / Subject to alterations!
Sous réserve de modifications! / Si fa riserva di modifiche!
Salvo modificação da construção! / Sujeto a modificaciones!

Printed in Germany.